

# MAINTENANCE & ADJUSTMENT

## Circuit Theory

The concept of PLL system frequency synthesization is not of recent development, however, it has not been a long age since the digital theory has been coupled with the PLL synthesization technology. Although details of the PLL theory is somewhat complicated and not within the scope of this brochure, we hereby provide the fundamental theory of it.

**PLL Circuitry.** PLL is an abbreviation of the phase-locked loop which is fundamentally composed of a closed loop feedback circuit. The feedback components is the balance of frequency drifts and PLL circuit acts to cancel it out. To detect out the frequency drift of the PLL output, a fixed reference oscillator (10KHZ, 1/1024 divided down from 10.240MHZ) is compared constantly with the input frequency (10KHZ). The input frequency is obtained by dividing the VCO frequency. A functional block diagram is provided below under "PLL Circuit" for the easier understanding.

$$F_{vco} = f \text{ off-set} + Nf_r$$

Where,  $f_{vco}$  = VCO frequency,  $N$  = programming code for divider output,  $f_r$  = reference frequency step, 0.01MHZ.

i.e. At channel #1 in band A, and AM band corresponding  $N$  code is 91.

### TRANSMITTER

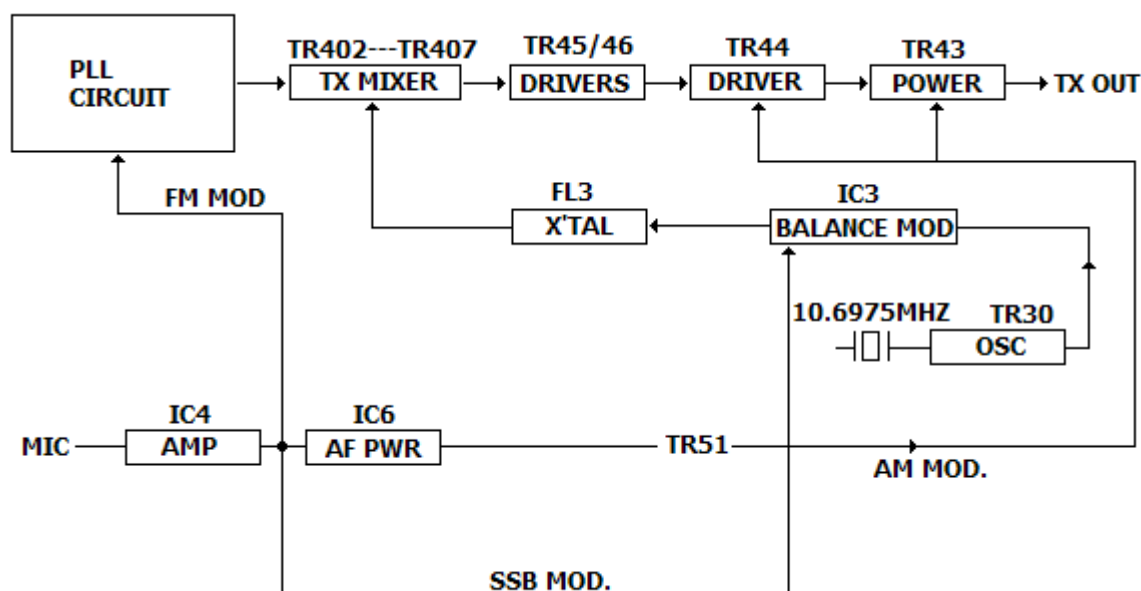

$$F_{vco} = 14.300 + 91 \times 0.01 = 15.210 \text{MHZ}$$

Since the mixer output is determined by two factors-the off-set frequency output (dependent on band selector switch) and the VCO output, the mixer output contains the subtracted frequencies of 0.91 to 2.25MHZ. These frequencies appear in pin #2 of IC803 through C105, and divided by the programmable divider in IC803 down to 10KHZ which is compared with another 10KHZ signal obtained from the reference oscillator (10.240MHZ). The VCO output is mixed with TR402—TR407 through band-pass filters L43 and L44 i.e.

### PLL CIRCUIT

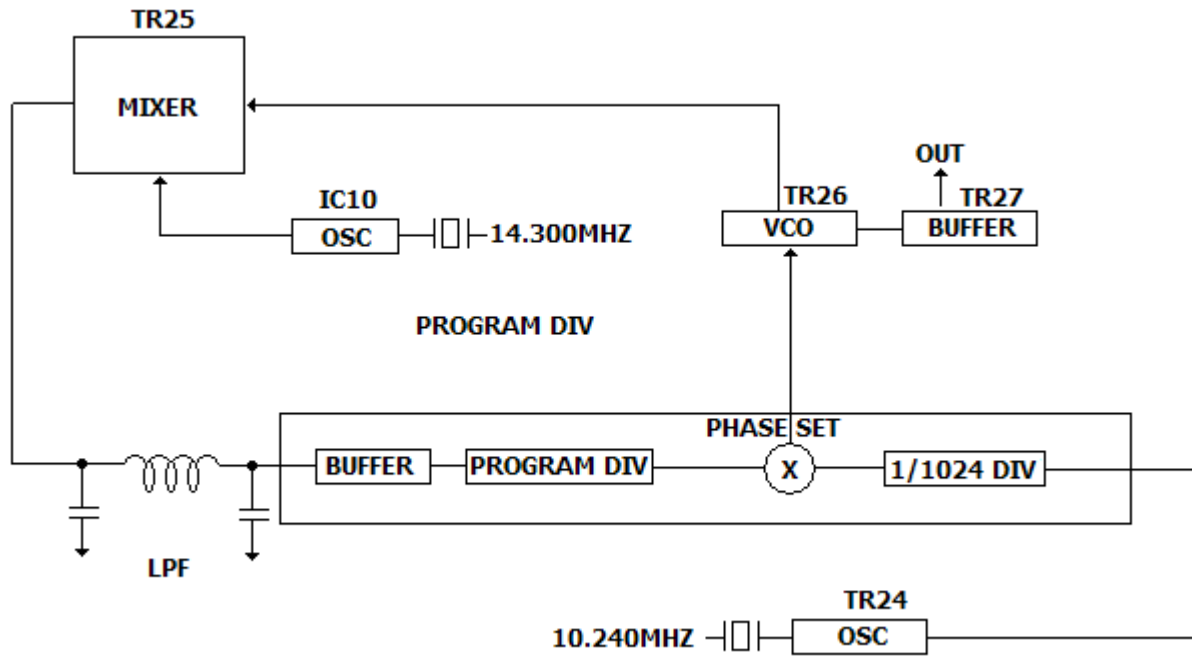

**RECEIVER**

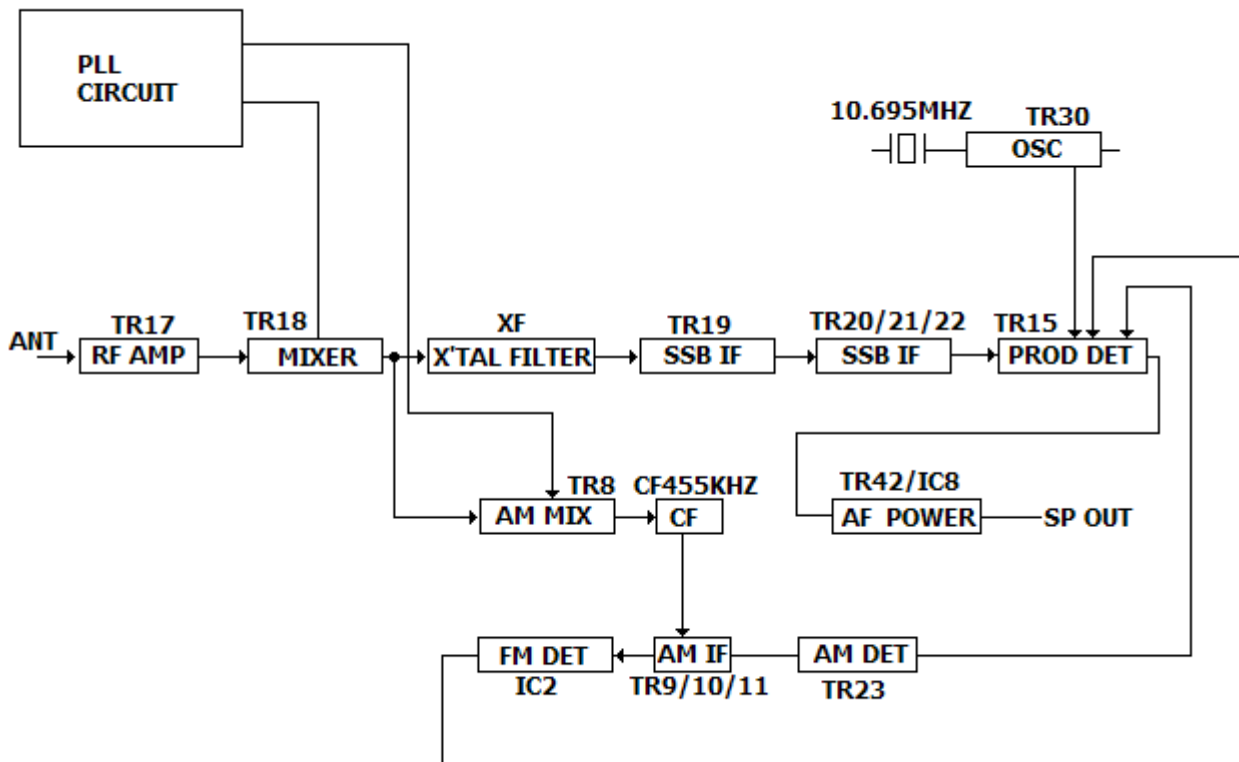

**Alignment Procedure**

**1 – Measurement Condition**

- 1) reference temperature 25°C

2) reference humidity 65%

Note: unless otherwise specified, alignment may be performed under the room temperature of 5°-35°C and the room humidity of 45-80%

3) power supply DC 13.8V

**2 - Test Equipment.** All test equipment should be properly calibrated.

- a) 50 Ohm resistive antenna load, 20W.
- b) frequency counter operable in the required frequency range.
- c) HF signal generator operable over 50KHZ to 60MHZ.
- d) synchroscope, 0-100MHZ, high input Z.
- e) FM deviation meter
- f) digital voltmeter
- g) 8 Ohms 5W resistive speaker load.
- h) two audio signal generators, 10Hz to 20KHZ, attenuative.
- i) RF wattmeter, 50Ohm/15Watt, thermocoupled.
- j) circuit tester, input impedance 20KOhm/V.
- k) Regulated DC power supply, more than 4A.
- l) Dummy microphone plugs, receive and transmit mode.
- m) VTVM, 0.1mV measurable.

### 3 – PLL Circuit Alignment

- A. [10.240MHZ] Reference Frequency Adjustment (Check)
  - 1) Connect frequency counter to pin terminal between C-78 and C79.
  - 2) Check counter reads 10.24000MHZ.
  - 3) Tolerance within +/- 200HZ is acceptable. Otherwise, replace X-1 (10.24MHZ).
- B. [10.9625/10.6975 MHZ]. Adjustment.
  - 1) Connect frequency counter to TP-6.
  - 2) 10.6925MHZ: Set mode selector to USB. Adjust L-27 to 10.6925MHZ, +0, -100HZ.
  - 3) 10.6975MHZ: Set mode selector to LSB. Adjust L-28 to 10.6975MHZ, +0, -100HZ.
- C. PLL input level adjustment.
  - 1) Set the mode selector to AM, and the clarifier control to center.
  - 2) Connect synchroscope to TP4 (pin terminal between the C82 and R107).
  - 3) adjust L16 for maximum RF output.
- D. [VCO] Adjustment
  - 1) set the mode selector to AM, and the clarifier control to center.
  - 2) connect synchroscope to TP3.
  - 3) Adjust L18 for maximum RF output.
  - 4) Connect DC voltmeter to TP2 (PIN terminal between R116 and R100 from IC803).
  - 5) Adjust L17 to DC 5.0/01V

### 4- Transmitter Alignment

- A. RF Power Transistor of Current Adjustment
  - 1) Set the mode selector to USB,
  - 2) connect current meter to TP9 (+) and TP8 (-).
  - 3) Adjust VR11 to 10+/-0.5mA.
  - 4) Connect current meter to TP9 (+) and TP8 (-).
  - 5) Adjust VR10 to 100+/-5mA.
- B. RF power amplifier Adjustment
  - 1) Set the mode selector to USB.
  - 2) Apply 1000Hz 30mV audio to microphone input circuit (use dummy microphone plug).
  - 3) Adjust VR12 and L40 for maximum RF output.
  - 4) Adjust L42, L43, L44 and L33 for maximum RF output.
  - 5) repeat step 3) through 5) until no further improvement is obtained.
  - 6) Adjust L40 for balance RF output.
- C. Two-Tone Adjustment
  - 1) Apply 500Hz and 2400Hz (30mV) audio tones to the microphone input circuit at the same time. Use two audio signal generator set with attenuators.
  - 2) Adjust test audio levels of 500Hz generator by means of attenuators on the generator so that the scope present wave figure like "A" as shows below.
  - 3) Adjust VR12 to 4Wpp power output.
- D. AM/FM RF power output adjustment
  - 1) set the mode selector to AM.

- 2) select the channel 20.
- 3) adjust VR13 for 4W RF power output.
- E. AM modulation adjustment
  - 1) apply 1000Hz 30mV audio to the unit.
  - 2) Adjust VR14 for modulation depth of greater than 90%.
- F. FM Deviation Adjustment
  - 1) Set the mode selector to FM
  - 2) Apply 1000Hz 30mV audio to modulation circuit. Use dummy microphone plug.
  - 3) Connect deviation meter (or linear detector) to antenna output on the unit.
  - 4) Adjust VR5 to obtain 2KHZ.
- G. RF Power Meter Adjustment.
  - 1) Set the mode selector to AM.
  - 2) Comparing the reading of external RF power and the built-in meter, adjust VR8 for equal indication on the unit power meter.

## 5 – Receiver Alignment

- A. AM Sensitivity Adjustment
  - 1) set signal generator to 26.965MHz 30% modulation.
  - 2) set the channel selector 01
  - 3) Set the mode selector to AM.
  - 4) Adjust L3, L4, L6, L7, L8, L10, L11, and L12 for maximum audio output from speaker output terminals (across dummy load).
  - 5) After completing above; adjust L8 for balance channels
- B. SSB sensitivity adjustment
  - 1) set signal generator to 26.966MHz without modulation.
  - 2) set the channel selector to channel 01
  - 3) set the mode selector to USB.
  - 4) adjust L13 and L14 for maximum audio output. Set clarifier to center.
- C. FM IF/demodulator Alignment (FM Sensitivity Adjustment)
  - 1) Select channel 01, set the mode selector to FM.
  - 2) set signal generator to 26.965MHz.
  - 3) apply FM signal (1uV, 1.5KHz deviation with 1KHz audio) to unit.
  - 4) readjust L5 for maximum audio output.
- D. Squelch adjustment
  - 1) set the mode selector to AM
  - 2) set signal generator to provide RF input signal of 60dB (1000uV,) 1KHz 30% modulated, and rotate squelch control to the fully clockwise position.
  - 3) Connect scope to speaker output terminal. Adjust VR4 to a point at which audio output is critically disappeared on scope. Check the squelch circuit will operate 48-70dB at all modes. SSB RX squelch is automatically adjust by VR3 and requires no particular adjustment.
- E. S-METER adjustment
  - 1) set the mode selector to AM
  - 2) adjust signal generator output to 40dB (100uV).
  - 3) adjust VR1 so that S-meter indicates “9”

## Operating procedure to Receive

**IMPORTANT:** make sure that the antenna, power source, and microphone are connected before you operate.

- 1) turn the unit on by setting the power switch to ON position. Now the meter, channel indicator, and function indicator will be illuminated.
- 2) Set the mode switch in AM position.
- 3) Set the squelch control in fully counterclockwise position and adjust the AF gain control for a comfortable listening level.
- 4) Listen to the background noise from the speaker. Turn the squelch control slowly clockwise until the noise just disappears (no signal should be present). Leave the squelch control at this setting. The squelch control is now properly adjusted. The receiver will remain quiet until a signal is actually received. Do not advance the squelch control too far clockwise or some of the weaker signal will not be heard.
- 5) Depress the clarifier and set it to the center (12 o'clock) position.
- 6) Select a desired mode of operation FM, AM, USB, LSB and adjust the clarifier.
- 7) Select a channel you desire .

Note. If you want to operate in between channels, pull out the clarifier knob and rotate it upscale or downscale. (this also affects in transmitting mode).

### **Operating procedure to transmit.**

- 1) select the desired channel and mode of transmission.
- 2) If the channel is clear, depress the push-to-talk switch on the microphone. Speak in a normal tone of voice. Stand by beep

A special provision has been built in your radio to give other station a sign which tells that you are turning to receive. Without needing switching operation to activate this feature, a beep tone is automatically transmitted at each time you release the push-to-talk switch on the microphone to turn to receive mode.

Microphone gain control.

A preamplifier circuit is built into the radio to increase the microphone gain. Experiment with the control for setting that will best suit your individual use.

Note: when the microphone gain control is set to maximum, ambient noise may also be picked up by the microphone. In high noise situations, low microphone gain setting may produce the best results.

### **SWR Measurement.**

Most antennas are factory tuned, but the antenna efficiency may be peaked by slightly adjusting the length of antenna using the SWR meter built into the unit. This adjustment may improve the antenna standing wave ratio (SWR). The SWR permits you to determine how well matched the antenna and its cables are to your transceiver.

- 1) set the unit in the receive mode as instructed under the operating procedure to receive section.
- 2) Set the mode switch to AM position; the SWR-cal switch to the call position.
- 3) Press the push-to-talk switch on the microphone and turn the calibrate control clockwise (past click) so that the SWR meter pointer exactly coincides with the set mark on the scale. Release the push-to-talk switch.
- 4) Set the SWR-cal switch to the SWR position and depress the push-to-talk switch again. The SWR of your antenna is read directly on the scale.

Note: an SWR below 2 or less is desired as this indicates that over 95% of the transmitted power is broadcast into the air.